

South Asia Co-operative Environment  
Programme (SACEP) Plastic free Rivers and Seas  
for South Asia (P171269)

ENVIRONMENTAL AND SOCIAL MANAGEMENT PLAN  
OF BIODEGRADABLE  
PLASTIC BAG PRODUCTION FACILITY -HANIMADHOO

GRANTEE : SMALL ISLAND GEOGRAPHIC SOCIETY - MALDIVES

Implemented by:



Supported by:



Supported by:



# Environmental and Social Management Plan (ESMP) Replacing Plastics in our Coastal Environment REPLACE Project

## 1. Subproject Information

<b>Subproject Title:</b>	Development of Biodegradable Plastic Bag Piolet Production Facility
<b>Estimated Cost:</b>	Construction USD 201,038 Setup USD 15,565 Equipment USD 56,745
<b>Start/Completion Date:</b>	1-Oct-2024 to 31-May-2024

## 2. Site/Location Description

Hanimadhoo Island, located in Haa Dhaalu Atoll at 6°45'N and 73°10'E, is the proposed site for a bioplastic production facility under the REPLACE project. The island, approximately 289 kilometers from Malé, covers 305 hectares and hosts the northernmost international airport in the Maldives. With a population of 2,664 (as of 2022), Hanimadhoo has a diverse economy that includes government employment, fisheries, agriculture, tourism, and trade. The proposed facility will be located on a plot of land located at 6°45'51.63"N 73°10'32.21"E, with an area of 4548.43 sqft. The land is a flat ground with only 2 trees as vegetation.

The land is subject to the northern Maldivian climate, with average temperatures ranging between 28.00°C – 28.40°C. The temperature increases during the months of March, April and May (28.50°C–29.05°C). Hanimadhoo in particular has the highest average monthly maximum temperatures from the weather stations in the country. The island receives on average 4-8 mm/day of rain annually. The land is accessible from Maaveyo Road, directly next to the plot. The land is located 309m from the harbour and 327m from the nearest beach.

Development of Biodegradable Plastic Bag Production Facility  
Location



Figure 1: Location Map



## Development of Biodegradable Plastic Bag Production Facility Location

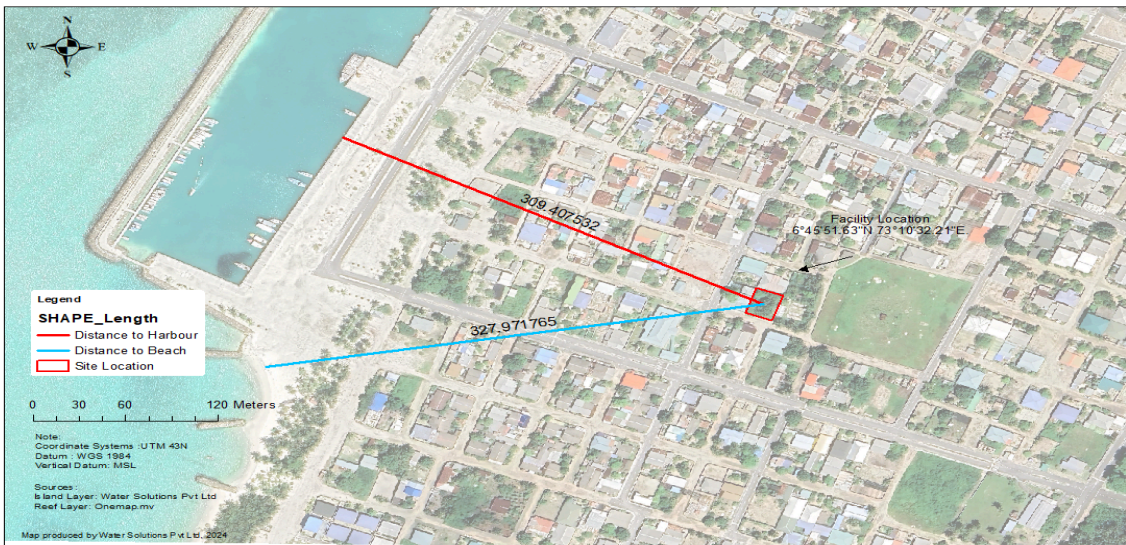

Figure 2: Map showing distance to beach and harbour



Figure 3: Photos of the site

The island was strategically chosen for the facility due to its proximity to potential raw materials such as banana peel, sea grass, rice waste from anticipated growth in tourism and catering, as well as cassava. Its economic significance further supports this selection. Agriculture is a key sector, with an agricultural center promoting the cultivation of crops like bananas and tomatoes for local markets. Employment opportunities are bolstered by regional infrastructure, including the international airport, a city hotel, the Hanimadhoo Agriculture Center, the Hanimadhoo Meteorological Office, and the Hanimadhoo Climate Observatory, a meteorological center. The growing tourism industry, supported by local guesthouses, adds to the economic vibrancy.

Electricity is primarily generated by diesel-powered generators managed by Fenaka Pvt Ltd., though renewable energy efforts are underway. Water and sanitation services are locally managed through rainwater harvesting, desalination, and groundwater use. Waste collection and management on the island is overseen by the Island Council, which employs a contractor to handle operations at the existing waste management center. A new waste management facility is proposed, aimed at improving

current practices. This facility is expected to boost local employment opportunities and contribute to the island's economic development.

### 3. Subproject Description and Activities

The proposed facility building consists of a two-story building with a terrace. The area of the proposed facility is 2590.04 sqft. This building will consist of a production facility, office, storage and related services. Below are the details of the proposed building.

#### Ground floor

- Courtyard
- Lobby area
- Production facility
- Kitchen
- Storage
- Security room
- Toilets
- Panel room
- Mezzarin floor
- Classroom
- Office

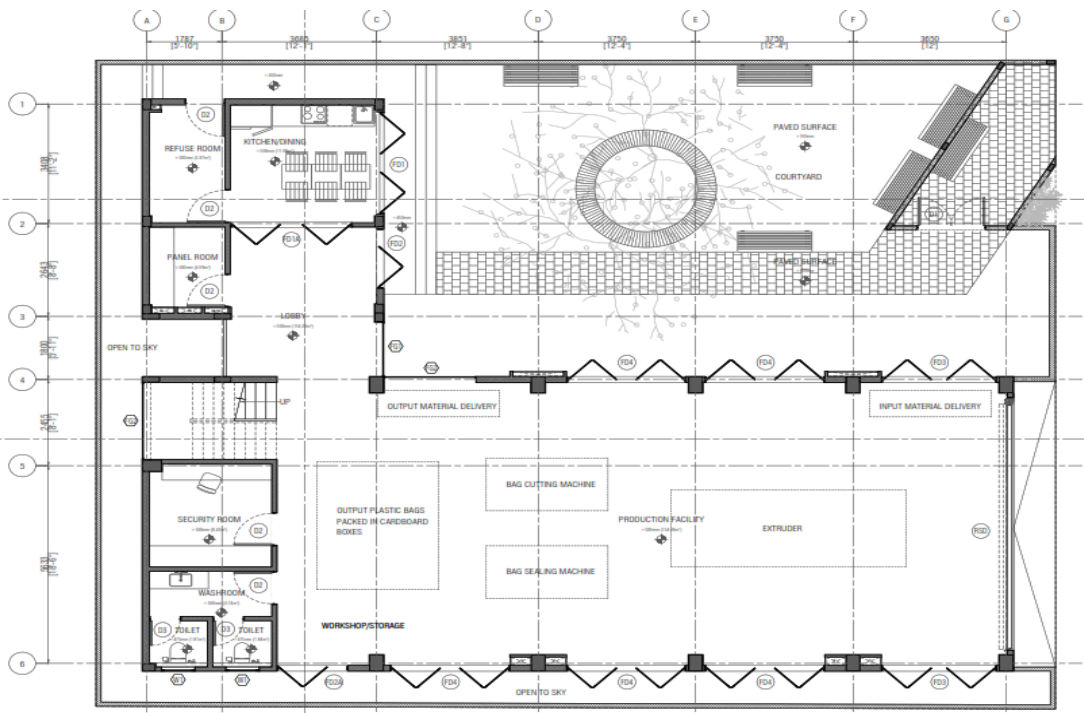

Figure 2: Ground floor layout. Building drawings are attached as an annex.



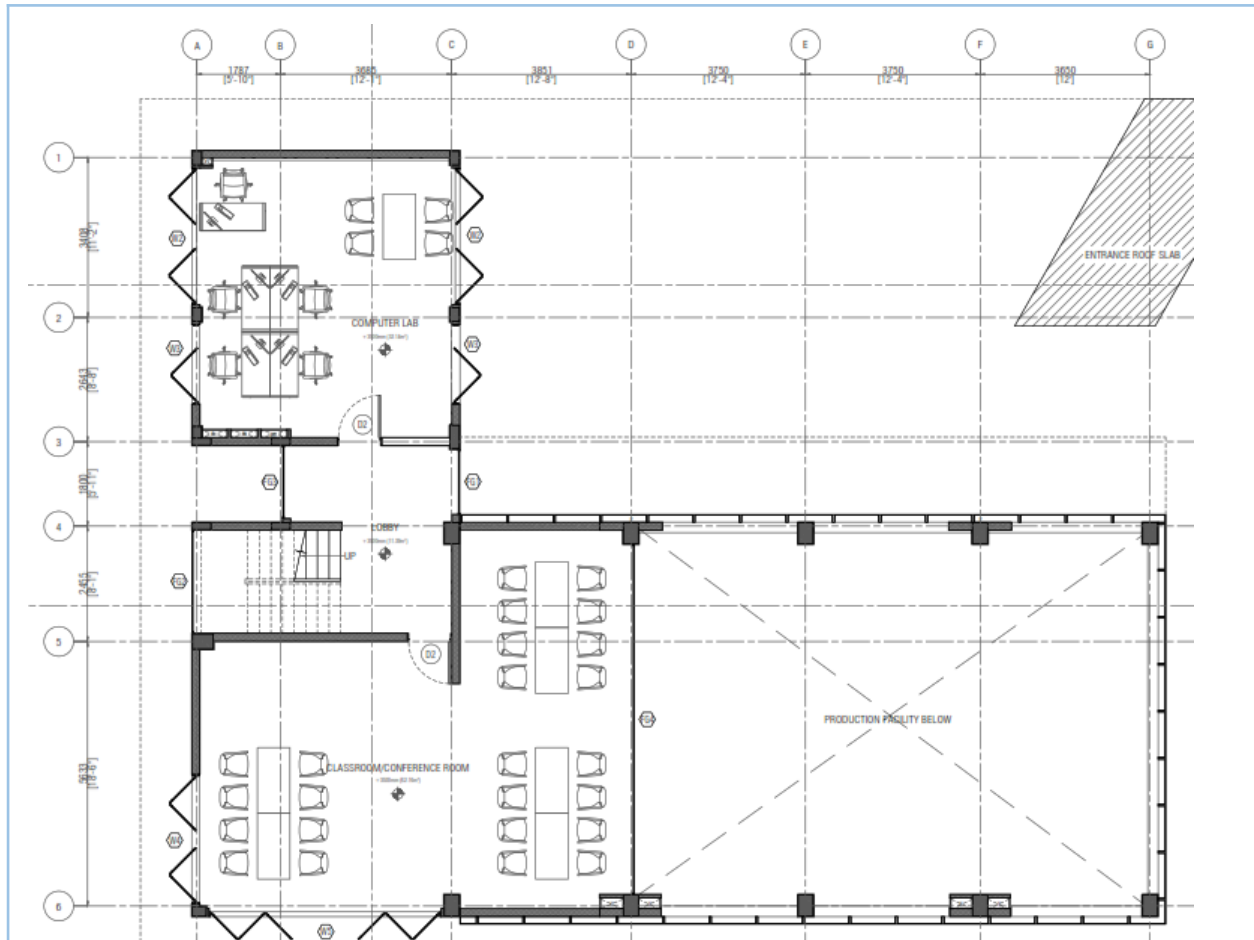

Figure 2: First floor layout where computer lab and classroom will be placed.

The two-story building has been designed by engineers to allow for future expansion, enabling the facility to evolve into a research center. This expanded facility will be capable of providing valuable research and applications specifically tailored to an island setting.

### Construction phase

The construction process will first consist of ground and foundation works, which will involve excavation of the site along with establishing pad footing foundations. Afterward, work will be undertaken on the 2 floors of the facility, each requiring concrete works, masonry, metal works, installation of electrics and hydraulics and drainage, along with other construction processes.

Water from the construction site will be filtered for silt and allowed to seep into the ground at the site, provided that the dewatering (if required) is not determined to cause harm to the aquifer. If dewatering is required, a permit from the Utility Regulatory Authority should be acquired, and neighbours to the site should be informed before any dewatering activities take place. During the operations phase any waste water will be discharged into the existing sewerage system following the national guidelines.

Below are the details of the main construction activities.

- **Site preparation**

The construction site will be cleared of any vegetation and debris that falls within the proposed building footprint. Afterward, the ground is leveled to provide a stable base for the foundation.

Accurate measurements and boundaries are established using surveying equipment by experienced surveyors to ensure precise construction.

- **Foundation Construction**

Trenches are dug to the required depth for the foundation. It has been established that the depth of the foundation will be -1.4 m below the existing ground level. The estimated depth of the water table in the area is -1.5m (to be confirmed later during the EIA field visit) from ground level. However, excavation depth may exceed foundation depth depending on the depth of adjacent footings. After a foundation has been established, wooden or metal formwork is placed to shape the concrete. Steel rebars are positioned within the trenches to reinforce the concrete. Concrete is mixed on-site or delivered pre-mixed and poured into the formwork to create the foundation.

- **Column and Beam Construction**

Formwork is elected for columns and beams according to the structural design. Steel reinforcement is installed within the formwork to provide strength. Afterward, Concrete is poured into the formwork for columns and beams and allowed to cure.

- **Wall Construction**

Bricks are laid using mortar to construct walls. The bricks are arranged in a pattern that ensures stability and strength. Once the brick walls are in place, they are plastered to provide a smooth finish and protect against environmental damage.

- **Roof Construction**

Wooden or steel trusses are installed to support the roof. Roofing materials such as tiles, shingles, or metal sheets are placed over the trusses to create the roof.

- **Finishing**

Ceramic or porcelain tiles are laid on floors and walls, particularly in wet areas such as bathrooms and kitchens. The interior and exterior walls are painted with weather-resistant paint. Electrical and plumbing fixtures are installed, along with doors, windows, and other fittings.

- **Landownership**

The land is owned by Water Solutions Ltd (see Annex 7.1. for land deed). The company has agreed to provide the 4,500 square foot parcel of land to SIGS in order to be able to establish the Facility (see Annex 7.2. for the Memorandum of Understanding).

**Operational Phase**

The project looks into pilot-producing plant-based bags and packaging to replace single-use plastic bags as these are not currently produced in the Maldives.

The bags produced will be biodegradable plastic bags made from plant-based starch granules. This approach addresses the problem of plastic bag accumulation in landfills by ensuring the bags biodegrade. By creating compostable bio-polymer bags, this solution provides an environmentally

friendly alternative. Additionally, it is important to evaluate the availability and presence of similar sustainable and eco-friendly bags in the Maldivian market to gauge their impact and acceptance.

Compostable bio-polymer bags are known to have similar mechanical properties as conventional plastic bags, with prices low enough to compete in the market. Sources for producing biopolymers include corn, sea grass, cassava and sugar beets. Compostable bags will be suitable for wet/organic waste disposal and will be printed in green – named “Fehi Kothalhu” (green bags). Water soluble bags also use pellets made using non-toxic, plant-based materials (such as cassava), poly-vinyl alcohol, vegetable oil derivatives, and non-plastic additives. To meet the EPA requirements, the bags will be EN - 13432 certified - which is a European certification that states that the product is certified biodegradable and compostable.

At a later stage of the project, the source raw materials will be replaced by locally identified materials through testing at the laboratory established as part of the REPLACE project. The goal at the end of the pilot bioplastic production project is to develop a viable commercial business model for alternative bioplastic bag production. Once the pilot phase concludes, the facility is planned to be handed over to Water Solutions. Depending on the success of the pilot, bioplastic production may be expanded to a commercial scale by Water Solutions. Potential target customers for the alternative bioplastic bags include individual businesses and supermarkets seeking alternative shopping bags, WAMCO, and the island council for municipal waste collection from households and businesses. Additionally, the biodegradable plastic film could be utilized for alternative packaging solutions for local food producers, such as packaging spices, snacks, and chips that are currently in single-use plastic.

**Producing biodegradable plastic bags typically requires the following:**

1. **Biodegradable Polymer Resins:** These are the key raw materials used in the production of biodegradable plastic bags. Commonly used biodegradable polymers include polylactic acid (PLA), polyhydroxyalkanoates (PHA), polybutylene succinate (PBS), and polyhydroxybutyrate (PHB). For the pilot production, bioresins THJS-5801 and THJS-6802 are being considered as raw materials. These bioresins are bio-based thermoplastic resins derived from plant-based materials, designed to replace conventional petroleum-based plastics in various industrial and consumer applications. Bioresins offer advantages such as a lower carbon footprint and biodegradability, making them ideal for environmentally sustainable products, particularly in the production of bioplastics.
2. **Additives:** Additives may need to be included in the production process to modify the properties of biodegradable polymer resins. Plasticizers, such as glycerol, would be added to improve the flexibility, softness, and workability of the bioplastic. Fillers, such as starch or cellulose fibers, may be used to reduce production costs and enhance mechanical properties like strength and rigidity. Stabilizers, such as UV stabilizers or antioxidants, would be included to protect the bioplastic from degradation caused by environmental factors such as heat, light, or oxygen. If coloring is required, natural pigments can be added to provide color and enhance the aesthetic appeal of the bioplastic product.
3. **Processing Equipment:** The bioplastic production process requires specialized machinery to convert raw material resin into bioplastic bags. An extrusion machine would change bioplastic



resin into a continuous profile. This profile is then fed into an automatic bag-making machine that cuts, seals, and prints on the material to produce various types of biodegradable bags, including flat bags and T-shirt bags. The combination of these machines ensures streamlined production, transforming the bioplastic resin into finished bags ready for use.

- **Extruders:** Extruder is used in plastic bag manufacturing to melt and shape polymer resin into a continuous profile. A single-screw extruder will be installed, capable of an output ranging from 20 to 60 kg/h and producing film with a thickness of 0.006 to 0.100 mm. The extruder requires 40 kW of power.
- **Bag Making Machines:** Automatic bag-making machines will be installed to convert the processed biodegradable plastic material into finished bags. The machine can produce both flat bags (without handles) and T-shirt bags (with handles). It is equipped to cut, seal and print on the bags. The machine operates with two lines, each capable of producing 40 to 150 bags per minute. It will handle bag thicknesses of 0.006 to 0.100 mm and supports sealing and cutting lengths between 100 to 1500 mm. The power requirement for the machine is 8 kW.

4. **Quality Control Measures:** To ensure the production of high-quality biodegradable plastic bags, quality control measures are essential. This includes avoiding storing pellets at temperatures above 40°C and maintaining dry and low humid conditions. Monitoring the composition of the raw materials, production process parameters, and the properties of the final product.

The following figures show the chosen and typical process steps for the production of biodegradable plastic bags from imported source material (pellets):

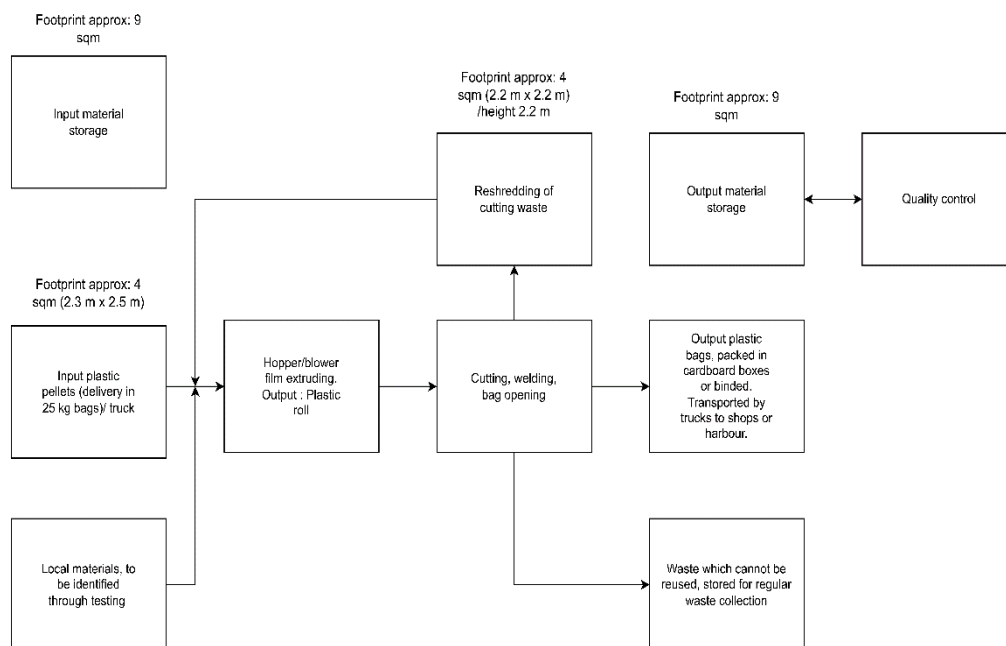

Figure 11: Process steps to produce biodegradable plastic bags from imported materials

5. Making bioplastic pellets from locally available raw materials. The process of creating bioplastic pellets begins with sourcing locally available materials such as banana peel, cassava, or seagrass. These materials first undergo a starch extraction process, where they are broken down to obtain the starch content. The extracted starch is then filtered to separate it from any impurities or non-starch components. Once purified, the starch is mixed with glycerin, vinegar, and water in a container. The mixture is stirred continuously over mild heat to achieve a sticky, homogeneous consistency. The heat helps activate the biopolymer properties of the starch, allowing it to combine with the other ingredients and form a pliable substance. This results in a bioplastic mixture that can be processed into pellets.
6. During the operation phase of the project 5 full time staff will be hired and trained to run the production facility. The details of these staff are included in the table below. The positions will be open to everyone and special consideration will be given for women to work in the field.

#	Position	Qty	Type	Gender	Training
1	Production Manager	1	Full-Time	TBA	Capacity building training will be provided, including training on how to use the facility equipment and health and safety measures
2	Supervisor	1	Full-Time	TBA	
3	Production staff 1	1	Full-Time	TBA	
4	Production staff 2	1	Full-Time	TBA	
5	Labourer	1	Full-Time	TBA	

#### 4. ESMP Matrix: Risk and Impacts, Mitigation, Monitoring

Find a table below detailing the anticipated environmental and social risks and impacts as a result of the project, as well as their mitigation and monitoring measures.

##### Construction Phase

Anticipated E&S Risks & Impacts	Risk Mitigation & Management Measures	Impact Mitigation		Impact/ Mitigation Monitoring			Monitoring & mitigation cost
		Location/Timing /Frequency	Responsibility	Indicator to be monitored	Methodology, Location & Frequency	Responsibility	
Air pollution – emissions from the construction equipment and vehicles can lead to disturbance and health hazards such as lung damage to both workers and nearby residents	Fit machinery and vehicles with exhaust systems and maintain the machinery and vehicles in good working condition.	Ongoing during construction	Site supervisor	Dust levels, Condition of exhaust systems. - Emission levels from machinery excavators during excavation, concrete machines, grinders, jackhammers, saws and vehicles.	Conduct inspections of machinery and vehicles for proper exhaust systems (every 3 months).	SIGS EHS Officer, Technical Expert from UNOPS Country Team	Practical measure that does not need additional cost
	Service equipment regularly to minimize emissions and maintain record	On-site. Per manufacturer's recommendations	Site supervisor, Equipment Maintenance Team	Maintenance logs. - Frequency of equipment servicing.	Review maintenance logs to ensure equipment servicing is done as per schedule	Contractor to keep the logs and SIGS EHS Officer to check the logs, Technical Expert	Equipment service is routine for vehicles. No additional cost.



Anticipated E&S Risks & Impacts	Risk Mitigation & Management Measures	Impact Mitigation		Impact/ Mitigation Monitoring			Monitoring & mitigation cost
		Location/Timing /Frequency	Responsibility	Indicator to be monitored	Methodology, Location & Frequency	Responsibility	
					(every 3 months). - Inspect equipment condition after servicing. - On-site.	from UNOPS Country Team	
	Take precaution to reduce level of dust from the earthworks by sprinkling water and controlling source of dust	On-site, particularly during earthworks.	Site supervisor	Dust levels on-site. Air quality (PM2.5 and 10)	Measure dust levels with air quality monitors (every 3 months)	SIGS EHS Officer, Technical Expert from UNOPS Country Team	200 USD for air quality meter rentals (every 3 months)
	Establish a Grievance Redress Mechanism (GRM) for affected residents to communicate their concerns ( annex 7.6)	Ongoing during construction	Site supervisor	Number and list of grievances  Status of grievance resolution	Review list and logs of submitted grievances (every 3 months)	SIGS EHS Officer, Technical Expert from UNOPS Country Team	450 USD for signage
Noise, Vibration & Disturbance to the community – noise could	Maintain noise levels at the boundary at 55 dB(A) during the	Ongoing during construction	Site supervisor for monitoring and enforcement	Noise levels (Decibels)	Sound level meters, monitored during peak	SIGS EHS Officer to review, Technical Expert	100 USD for noise meter rentals

Anticipated E&S Risks & Impacts	Risk Mitigation & Management Measures	Impact Mitigation		Impact/ Mitigation Monitoring			Monitoring & mitigation cost
		Location/Timing /Frequency	Responsibility	Indicator to be monitored	Methodology, Location & Frequency	Responsibility	
<p>disrupt the daily activities and sleep of community members.</p> <p>Risk of hearing damage to workers from prolonged exposure to noise from machinery</p>	daytime and 45 dB(A) at night.				activities (every 3 months)	from UNOPS Country Team	
	Minimise or avoid any high noise-generating activities during the night-time, below 45 dB(A)	Throughout the project, particularly during noise-sensitive hours (e.g., nighttime)	Site supervisor to schedule and monitor night-time activities	Noise levels (Decibels) & Timing of noise-generating activities.	Monitor work schedules and ensure compliance with restricted noise-generating activities at night (every 3 months)	SIGS EHS Officer, Technical Expert from UNOPS Country Team	100 USD for noise meter rentals
	Provide earmuffs to workers on site.	During high noise-generating activities or continuous loud operations	Site supervisor	Availability and use of earmuffs by workers.	Conduct PPE checks to ensure workers have earmuffs and are wearing them in noise hazard areas.	Site supervisor SIGS EHS Officer, Technical Expert from UNOPS Country Team	800 USD for the PPE
	Establish a GRM for community concerns (annex 7.6)	Ongoing during construction, as grievances are submitted	Site supervisor	Number and list of grievances  Status of grievance resolution	Review list and logs of submitted grievances (every 3 months)	SIGS EHS Officer, Technical Expert from UNOPS Country Team	450 USD for signage

Anticipated E&S Risks & Impacts	Risk Mitigation & Management Measures	Impact Mitigation		Impact/ Mitigation Monitoring			Monitoring & mitigation cost
		Location/Timing /Frequency	Responsibility	Indicator to be monitored	Methodology, Location & Frequency	Responsibility	
Waste generation	Implement measures to reduce waste generation – Reduce packaging, ensure packaging is only used, when necessary, order in bulk to reduce total packaging used Use recyclable materials where possible, to reduce energy consumption and toxic waste Use sustainable practices such as recycling food order cartons, limit materials ordered to reduce waste	During procurement and construction process	Site supervisor / Procurement specialists	Volume of waste generated. Usage of recyclable materials.	Track waste generation rates via waste logs (every 3 months).	Site supervisor to keep logs and SIGS EHS Officer to review, Technical Expert from UNOPS Country Team	Practical measure that does not need additional cost



Anticipated E&S Risks & Impacts	Risk Mitigation & Management Measures	Impact Mitigation		Impact/ Mitigation Monitoring			Monitoring & mitigation cost
		Location/Timing /Frequency	Responsibility	Indicator to be monitored	Methodology, Location & Frequency	Responsibility	
	Ensure disposal methods for different types of waste, including hazardous materials, and adhere to local regulations.	On-site, during the construction phase.	Site supervisor	Compliance with waste disposal regulations. - Proper waste disposal	Inspect waste handling areas and hazardous material storage (every 3 months).	Site supervisor to keep records and SIGS EHS Officer to inspect, Technical Expert from UNOPS Country Team	50 USD per bin for separate bins
	Leftover construction materials that cannot be reused should be taken back by the contractor at the end of the project.	At the end of the project, with periodic checks during construction for material reuse opportunities	Site supervisor to oversee material return -	Inventory of leftover construction materials.	Maintain a record of leftover materials (end of project). - On-site.	Site manager to keep records and SIGS EHS Officer to inspect, Technical Expert from UNOPS Country Team	1500 USD per trip (Hanimaadhoo to Vandhoo).
Waste Water	Understand the quality, quantity, frequency and sources of liquid effluents Plan and implement segregation of liquid effluents Identify opportunities to prevent or	Throughout implementation					

Anticipated E&S Risks & Impacts	Risk Mitigation & Management Measures	Impact Mitigation		Impact/ Mitigation Monitoring			Monitoring & mitigation cost
		Location/Timing /Frequency	Responsibility	Indicator to be monitored	Methodology, Location & Frequency	Responsibility	
	reduce waste water pollution through recycling, reusing Assess compliance of wastewater discharges with the discharge standard, water quality standard for specific reuse (eg irrigation).						
Water Contamination (chemical spills, sedimentation)	storage and handling of chemicals. - label all containers with chemicals - Store chemicals based on compatibility to avoid reactions. - Use of spill containment systems. - Chemical containers once	At start of construction, then review every 3 months	Site supervisor	Water quality parameters (pH, turbidity, contaminant).	Water sampling and analysis from groundwater samples. (every 3 months)	SIGS EHS Officer to inspect, Technical Expert from UNOPS Country Team	1500 USD for spill containment materials  400 USD for water quality monitoring

Anticipated E&S Risks & Impacts	Risk Mitigation & Management Measures	Impact Mitigation		Impact/ Mitigation Monitoring			Monitoring & mitigation cost
		Location/Timing /Frequency	Responsibility	Indicator to be monitored	Methodology, Location & Frequency	Responsibility	
	used and ready to be taken away as waste should be stored separately in a locked bin, for safe collection from the waste service						
Risk of accidents and pollution on workers and local populations	Training of all workers on occupational health and safety (OHS) before construction works.	Before the start of construction work, with periodic refresher courses.	Site supervisor	Number of workers trained	Training prior to commencement of construction activities. Maintain training logs and attendance records. Routine toolbox meetings to ensure ongoing safety and compliance. Records reviewed every 3 months.	SIGS EHS Officer to inspect, Technical Expert from UNOPS Country Team	500 USD for all the training materials
	Signages installed to identify all areas at work sites, including hazardous areas.	During equipment and material setup, with ongoing	Site supervisor	Presence and condition of signages	Inspect the placement and legibility of signages (every 3 months).	SIGS EHS Officer to inspect, Technical Expert from UNOPS Country Team	450 USD for signage

Anticipated E&S Risks & Impacts	Risk Mitigation & Management Measures	Impact Mitigation		Impact/ Mitigation Monitoring			Monitoring & mitigation cost
		Location/Timing /Frequency	Responsibility	Indicator to be monitored	Methodology, Location & Frequency	Responsibility	
		checks and updates					
	Avoidance of slips and falls through good house-keeping practices, and marked corridors, and use of slip retardant footwear.	Continuously throughout the construction phase	Site supervisor	Cleanliness of work areas. - Safe storage of materials.	Conduct inspections of work areas to ensure materials are properly stored and walkways are clear (every 3 months).	SIGS EHS Officer to inspect, Technical Expert from UNOPS Country Team	800 USD for PPE
	Adequate lighting in dark working areas and areas with night works.	During construction and night works, with periodic checks for maintenance	Site managers ensuring proper lighting	Lighting levels.	Inspect lighting installations in dark and night work zones (at start of construction).	Site Supervisor Safety Officer, SIGS EHS Officer, Technical Expert from UNOPS Country Team	Practical measure that does not need additional cost
	Ensuring the workplace can withstand severe weather conditions.	During construction and regularly assessed for weather resilience	Site managers / Structural engineers	Weather resistance of buildings and structures.	Inspect and reinforce workplace structures based on weather forecasts (seasonally, pre- and post-severe weather events).	SIGS EHS Officer to inspect, Technical Expert from UNOPS Country Team	Practical measure that does not need additional cost and included in construction costs

Anticipated E&S Risks & Impacts	Risk Mitigation & Management Measures	Impact Mitigation		Impact/ Mitigation Monitoring			Monitoring & mitigation cost
		Location/Timing /Frequency	Responsibility	Indicator to be monitored	Methodology, Location & Frequency	Responsibility	
					- On-site in areas prone to weather damage (roofs, walls, windows, drainage systems).		
	Establish a GRM for affected community members to communicate their concerns (annex 7.6)	Ongoing during construction, as grievances are submitted	Site supervisor	Number and list of grievances  Status of grievance resolution	Review list and logs of submitted grievances (every 3 months)	SIGS EHS Officer, Technical Expert from UNOPS Country Team	450 USD for signage
Risk of injury to labour force due to worker error	<ul style="list-style-type: none"> <li>- Provide PPE to workers</li> <li>- Conduct safety awareness training before the start of the construction works</li> <li>- Conduct daily toolbox talks before the start of the workday</li> </ul>	Ongoing during construction	Site supervisor	Number of safety incidents	Incident reporting / Monthly	Project management team (SIGS)	800 USD for the PPE
Risks of Sexual Exploitation and Abuse (SEA) and	-Appoint a PSEA Focal Point at the site.	Training and awareness will be conducted	Site Supervisor	Number of training sessions	Monthly site visit	SIGS EHS Officer, Technical Expert	200 USD Training costs

Anticipated E&S Risks & Impacts	Risk Mitigation & Management Measures	Impact Mitigation		Impact/ Mitigation Monitoring			Monitoring & mitigation cost
		Location/Timing /Frequency	Responsibility	Indicator to be monitored	Methodology, Location & Frequency	Responsibility	
Sexual Harassment (SH) between Project workers; and between Project workers and local community members	<p>-Provide awareness training on recognizing, and preventing SEA/SH for a) Project workers, and b) affected communities</p> <p>- Provide training on the GRM, including for SEA/SH related grievances to a) Project workers, and b) affected communities</p> <p>-Request all Project workers to sign a Code of Conduct (CoC) including instructions of SEA/SH prevention</p> <p>-Provide specific SEA/SH response mechanism as part of the Project GRM</p>	<p>prior to the commencement of work</p> <p>Implementation of Focal Points and signing of CoC at the site during the construction period</p>	UNOPS Gender officer	<p>provided to workers</p> <p>Number of awareness sessions provided to communities</p> <p>Number of SEA/SH Focal Points appointed</p> <p>Complaint box Actions taken in response to complaints</p>		from UNOPS Country Team	



Anticipated E&S Risks & Impacts	Risk Mitigation & Management Measures	Impact Mitigation		Impact/ Mitigation Monitoring			Monitoring & mitigation cost
		Location/Timing /Frequency	Responsibility	Indicator to be monitored	Methodology, Location & Frequency	Responsibility	
	-						
Potential for social issues related to labor influx	-Worker grievance meetings will be held regularly -Awareness on communicable diseases and awareness on Gender-based violence will be conducted Ensure that the contact details of the PSEA focal point are placed on notice boards in the project location	Prior to commencement of works	Site Supervisor  UNOPS Gender officer	Minutes of meetings are available  Number of awareness sessions	Monthly site visit	SIGS EHS Officer, Technical Expert from UNOPS Country Team	Training costs as part of SEA/SH awareness above
Non-compliance with the local regulatory requirements and workers dissatisfaction due to extensive work requirements	- Wages will be paid in accordance with the LMP of the project - Prevent all forms of forced labour and child labour	Throughout implementation of works	Site Supervisor  Contractor HR	Availability of workers' GRM  Availability of records of workers	Monthly site visit	SIGS EHS Officer, Technical Expert from UNOPS Country Team	

Anticipated E&S Risks & Impacts	Risk Mitigation & Management Measures	Impact Mitigation		Impact/ Mitigation Monitoring			Monitoring & mitigation cost
		Location/Timing /Frequency	Responsibility	Indicator to be monitored	Methodology, Location & Frequency	Responsibility	
	Keep records of age of all workers - Provide workers' GRM						
Lack of inclusion of vulnerable groups in key-holder consultations	Identify vulnerable groups at the site 1. Ensure distinct consultations with members of vulnerable groups as per the Project SEP	Throughout implementation of works	Site Supervisor	Number of site-specific consultations with members of vulnerable groups	Monthly site visit	SIGS EHS Officer, Technical Expert from UNOPS Country Team	Consultation cost
Lack of responsiveness of GRM	Create awareness of Project GRM among local community	Throughout implementation of works	Site Supervisor	Number of awareness sessions held	Monthly site visit	SIGS EHS Officer, Technical Expert from UNOPS Country Team	Costs of awareness sessions included in other awareness sessions above

**Operational Phase**

Anticipated E&S Risks and Impacts	Risk Mitigation and Management Measures	Impact Mitigation		Impact/Mitigation Monitoring			Monitor and mitigation cost
		Location/Timing /Frequency	Responsibility	Parameter to be monitored	Methodology, Location and Freq.	Responsibility	
Air quality – emissions from extruder and packaging machine and vehicles, which could cause health impacts on both workers and neighbors	Installation of ventilation system in the facility	On-site, during operation, Every 6 months	Site supervisor	Dust levels on-site. Air quality (PM 2.5 and PM 10)	Measure dust levels with air quality monitors-on-site( bi-bi-annually).	SIGS EHS Officer, Technical Expert from UNOPS Country Team	A ventilation system is included in the facility design. No additional cost.  200 USD for air quality meter rentals
	Establish a Grievance Redress Mechanism for affected residents to communicate their concerns (attached in annex)	On-site during operation, as grievances are submitted	Site supervisor	Number and list of grievances  Status of grievance resolution	Review list and logs of submitted grievances (quarterly)	SIGS EHS Officer, Technical Expert from UNOPS Country Team	450 USD for signage
Noise Pollution - Noise from extruder, packaging machine, compressors, conveyors, ventilation system and transportation could disturb local communities, and prolonged exposure could cause	Maintain noise levels at the boundary at 55 dB(A) during the daytime. The facility will not operate at night.  Avoid using multiple loud noise generating equipment simultaneously	On-site, during operation, Every 6 months	Site supervisor	Noise level in dB	Measure noise level with noise meter - on site (bi-annually).	SIGS EHS Officer, Technical Expert from UNOPS Country Team	Practical measure that does not need additional cost  100 USD for noise meter rentals  800 USD for PPE

Anticipated E&S Risks and Impacts	Risk Mitigation and Management Measures	Impact Mitigation		Impact/Mitigation Monitoring			Monitor and mitigation cost
		Location/Timing /Frequency	Responsibility	Parameter to be monitored	Methodology, Location and Freq.	Responsibility	
hearing damage to the workers	<p>Minimize or avoid any high noise-generating activities during the night-time.</p> <p>Avoid scheduling material transport during prayer times and school hours during weekdays.</p> <p>Equipment that produces a high level of noise should be kept in enclosed areas</p> <p>Workers should be provided with PPE in the form of earmuffs</p>						
	Establish a Grievance Redress Mechanism for affected residents to communicate their concerns (attached in annex)	On-site during operation, as grievances are submitted	Site supervisor	Number and list of grievances  Status of grievance resolution	Review list and logs of submitted grievances (quarterly)	SIGS EHS Officer, Technical Expert from UNOPS Country Team	450 USD for signage
Generation of waste waste due to chemical contaminations	Waste Water and chemicals passing through the Bioplastic facility sink should be stored and diverted through a chemical diluting	On - site during operation, through out the project period	Production facility operator	Water quality testing	Water quality Quarterly testing via water sampling, sent for testing at	Production facility operator	300 USD for water quality testing

Anticipated E&S Risks and Impacts	Risk Mitigation and Management Measures	Impact Mitigation		Impact/Mitigation Monitoring			Monitor and mitigation cost
		Location/Timing /Frequency	Responsibility	Parameter to be monitored	Methodology, Location and Freq.	Responsibility	
	tank and a chemical neutralization tank, where the wastewater is treated to reach target water quality standards, before being discharged into the existing sewer network.				qualified laboratory		
<p>Groundwater contamination – spills or leaks of solvents or additives</p> <ul style="list-style-type: none"> <li>- Improper handling of biopolymer compounds</li> <li>- Leachate from Waste Storage</li> </ul> <p>The above could lead to pollution of the water lens of the island, potentially causing harm to users of the islands' groundwater</p>	<p>Ensure proper handling and storage of chemicals.</p> <p>Regularly inspect drainage systems to avoid leakages.</p>	On-site, during operation, Every 6 months	Site supervisor	Total inventory and storage conditions of chemicals	Inspect chemical storage area, quarterly	SIGS EHS Officer, Technical Expert from UNOPS Country Team	Practical measure that does not need additional cost
	Take monthly groundwater (in situ) samples to test to assure no contamination is being done.	On-site, quarterly	Site supervisor	pH, COD and BOD	Groundwater quality testing –laboratory (quarterly).  Review monthly water test results	SIGS EHS Officer, Technical Expert from UNOPS Country Team	400 USD for water quality monitoring
	Establish a Grievance Redress Mechanism for affected residents to communicate their concerns (attached in annex)	On-site during operation, as grievances are submitted	Site supervisor	Number and list of grievances  Status of grievance resolution	Review list and logs of submitted grievances (quarterly)	SIGS EHS Officer, Technical Expert from UNOPS Country Team	450 USD for signage

Anticipated E&S Risks and Impacts	Risk Mitigation and Management Measures	Impact Mitigation		Impact/Mitigation Monitoring			Monitor and mitigation cost
		Location/Timing /Frequency	Responsibility	Parameter to be monitored	Methodology, Location and Freq.	Responsibility	
Waste Generation - including plastic residues, packaging, and other operational waste.	<p>Promote the reuse of by-products where possible.</p> <p>Develop and implement a waste management plan with clear separation and recycling processes.</p> <p>Waste should be collected frequently to ensure it does not stockpile and lead to smells or overflow.</p> <p>Limit use of packaging-order in bulk when necessary to minimize waste</p>	On-site, during operation, Every 6 months	Site supervisor	Volume of waste and type of waste generated	waste audit (bi-annually)	SIGS EHS Officer, Technical Expert from UNOPS Country Team	50 USD per bin for separate bins
Energy Consumption is estimated to be 400kWh/day - contributing to a larger carbon footprint.	<p>Implement energy-saving practices.</p> <p>Turn off unused equipment Use energy efficient lighting</p> <p>Monitor monthly energy consumption levels</p> <p>Use energy efficient equipment, such as energy saving bulbs</p>	Throughout the facility, Continuous energy-saving practices, annual energy efficiency audits.	Site supervisor	Energy consumption in kWh.	Electricity bills (bi-annually)	SIGS EHS Officer, Technical Expert from UNOPS Country Team	<p>Practical measure that does not need additional cost</p> <p>Cost for lighting included in construction</p>



Anticipated E&S Risks and Impacts	Risk Mitigation and Management Measures	Impact Mitigation		Impact/Mitigation Monitoring			Monitor and mitigation cost
		Location/Timing /Frequency	Responsibility	Parameter to be monitored	Methodology, Location and Freq.	Responsibility	
Chemical Hazard Risks – Leakage and spills into facility and ground, irritation and harm to workers when handling chemicals during the production process.	<p>Store chemicals in properly labeled, sealed containers in designated areas to prevent spills and leaks. In addition, store incompatible chemicals separately to prevent dangerous reactions.</p> <p>Train workers on emergency response procedures, such as spill response, evacuation routes and first aid measurements. Ensure workers are wearing PPE when working with chemicals.</p> <p>Chemical containers once used and ready to be taken away as waste should be stored separately in a locked bin, for safe collection from the waste service</p>	<p>During storage setup and continuously throughout chemical use and storage</p> <p>Before work begins and with periodic drills and updates as needed.</p> <p>Continuously throughout the construction phase</p>	Site supervisor	<p>Labeling of containers. - Condition of chemical storage areas.</p> <p>Attendance at emergency response training.</p>	<p>Inspect chemical storage areas for labeling and sealing (every 3 months).</p> <p>Check storage conditions - segregate incompatible chemicals (every 3 months).</p> <p>Keep training logs for spill response and first aid (every 3 months).</p> <p>On-site at emergency assembly points and training locations.</p> <p>Inspect waste handling areas and hazardous material storage (every 3 months).</p>	SIGS EHS Officer to inspect, Technical Expert from UNOPS Country Team	<p>500 USD for all the training materials</p> <p>800 USD for PPE</p> <p>50 USD for separate bin</p>

Anticipated E&S Risks and Impacts	Risk Mitigation and Management Measures	Impact Mitigation		Impact/Mitigation Monitoring			Monitor and mitigation cost
		Location/Timing /Frequency	Responsibility	Parameter to be monitored	Methodology, Location and Freq.	Responsibility	
					SIGS EHS Officer to inspect, Technical Expert from UNOPS Country Team		
OHS risks for workers	Provide personal protective equipment (PPE).  Conduct health and safety training annually.	Facility's operational areas, Continuous use of PPE and monthly safety drills.	Site supervisor	Number of incidents, safety compliance rates.	Incident reports and safety inspections bi-annually.	SIGS EHS Officer, Technical Expert from UNOPS Country Team	1500 USD for spill containment materials  500 USD for all the training materials  800 USD for PPE
Bioplastic bags can fail to break down if they are disposed improperly. This can occur through poor facility conditions or if they are mixed with other waste.	Improve composting facilities to ensure proper disposal of bioplastic bags where they can break down effectively. Integrate biodegradable waste streams into existing waste management systems and separate collection of compostable materials. Promote public education and awareness about the proper disposal of bioplastics to avoid recycling stream contamination.	Regular checks	Production facility operator	the volume of biodegradable plastic coming into the waste management site.	Regular inspection of composting facilities to track the volume of biodegradable plastic processed. Conduct Waste audits to monitor the separation of biodegradable plastics from non-biodegradable waste streams.	Production facility operator / Waste management facility operator	To be determined later once the facility start mass production

Anticipated E&S Risks and Impacts	Risk Mitigation and Management Measures	Impact Mitigation		Impact/Mitigation Monitoring			Monitor and mitigation cost
		Location/Timing /Frequency	Responsibility	Parameter to be monitored	Methodology, Location and Freq.	Responsibility	
<p>Biodegradation in Marine Environments – Bioplastic bags will break down into less harmful substances, reducing potential harm to marine life.</p> <p>Degradation of bioplastics in the marine environment is slower than composting facilities. Materials can still pose a risk to marine life before it degrades.</p>	<p>Ensure bioplastics are designed to fully degrade in both terrestrial and marine environments.</p>	<p>During the bag production</p>	<p>SIGS</p>	<p>Degradation capacity of the bags</p>	<p>Regular material degradation studies in controlled marine environments.</p>	<p>SIGS lab technicians</p>	<p>Setting up the laboratory is included as part of the project</p>
<p>Risk of carbon footprint</p>	<p>Reduction – Using bioplastic bags from locally sourced materials reduces reliance on imported plastics</p> <p>Educate public on the benefit of using bioplastic bags to create demand</p>	<p>Throughout the project period</p>	<p>Production facility operator</p>	<p>Public awareness</p>	<p>Monitor public education effectiveness through surveys</p>	<p>Production facility operator / Waste management facility operator</p>	<p>To be determined later once the facility start mass production</p>
<p>Risk of bags being unaffordable</p>	<p>Ensure the prices of biodegradable bags remain competitive with conventional plastic bags to encourage adaptation by both business and individuals.</p>	<p>Annually.</p>	<p>Production facility operator</p>	<p>Relative price of bioplastic bags compared to conventional bags. Profitability of producing and selling bioplastic bags.</p>	<p>Regularly compare the prices of bioplastic bags to conventional bags. Conduct a cost benefit analysis to evaluate long-term</p>	<p>Production facility operator</p>	<p>To be determined later during the mass production</p>

Anticipated E&S Risks and Impacts	Risk Mitigation and Management Measures	Impact Mitigation		Impact/Mitigation Monitoring			Monitor and mitigation cost
		Location/Timing /Frequency	Responsibility	Parameter to be monitored	Methodology, Location and Freq.	Responsibility	
					economic benefits of bioplastic bags, including reduced waste disposal costs and environmental benefits (bi – annually).		
Risk that local communities do not use bioplastics	Ensure that use of bioplastics supports local agricultural and production industries by creating a demand for local materials (banana peel and cassava), boosting local income and stimulating the island economy. Provide training and financial incentives to local farmers to supply raw materials. Ensure that increased demand for agricultural products does not negatively affect food production or prices. Encourage use of agricultural waste products to minimize competition with food production.	Annually.	Production facility operator	Percentage of raw materials sourced locally for bioplastic production.	Track local economic indicators to assess the impact of biodegradable plastic production and use (bi – annually).	Production facility operator / Waste management facility operator	3000 USD annually for training (this may change depending on the type and duration of training and awareness sessions)

Anticipated E&S Risks and Impacts	Risk Mitigation and Management Measures	Impact Mitigation		Impact/Mitigation Monitoring			Monitor and mitigation cost
		Location/Timing /Frequency	Responsibility	Parameter to be monitored	Methodology, Location and Freq.	Responsibility	
Lack of support from government bodies	Regular communication with island council and other government stakeholders  Raising awareness as to the environmental benefits of using bioplastic bags	Throughout the project period	Production facility operator	Opinion of government stakeholders	Monitor through meetings and communication with government stakeholders	Production facility operator	To be determined later once the facility start mass production
Lack of social acceptance of produced bags	Educate public on the benefit of using bioplastic bags to create demand, including reaching out to schools and local educational facilities	Throughout the project period	Production facility operator	Public opinion	Monitor public education effectiveness through surveys	Production facility operator	To be determined later once the facility start mass production
Lack of appropriate labor and working conditions	Adopt and implement LMP Provide workers' GRM	Throughout operational phase	Production facility operator	Availability of worker GRM	Monitor through site bimonthly site visits	Production facility operator	
Risk of SEA/SH incidents among workers	Prepare CoC with references to zero tolerance of SEA/SH Ensure all workers sign CoC Create awareness of CoC among workers	Throughout operational phase	Production facility operator	Availability of CoC Percentage of workers that have signed CoC Number of awareness sessions	Monitor through site bimonthly site visits	Production facility operator	

Anticipated E&S Risks and Impacts	Risk Mitigation and Management Measures	Impact Mitigation		Impact/Mitigation Monitoring			Monitor and mitigation cost
		Location/Timing /Frequency	Responsibility	Parameter to be monitored	Methodology, Location and Freq.	Responsibility	
Conflicts over employment opportunities at the facility	Ensure information about project is provided to communities Adopt and implement Project GRM	Throughout operational phase	Production facility operator	Number of information session with communities Availability of Project GRM	Monitor through site bimonthly site visits	Production facility operator	



## 5. Capacity Development & Training

To ensure the implementation of the pilot bioplastic production facility at Hanimadhoo, capacity building, training initiatives and the recruitment of new staff will be carried out. Any grievances on behalf of the staff or contracted workers can be dealt with via the Grievance Redress Mechanism, shown in the Labour Management Procedure attached in the annex.

### **Construction Phase**

Construction workers will be trained in health and safety measures, workers' GRM, SEA/SH issues, labor rights and conditions, Code of Conduct, and other relevant E&S risk mitigation measures from this ESMP. Community members in the surrounding communities will receive awareness sessions on the Project GRM, SEA/SH prevention and response, and safety issues in relation to the construction site.

### **Operational Phase**

A training program will be designed for facility workers to enhance their technical expertise in bioplastic production, focusing on processes such as material preparation, extrusion and quality control. This training will be provided by experts from bioplastic technology providers and training institutes.

Workers will further receive training on environmental and social risk management to ensure compliance with this ESMP. The training will cover waste management, pollution prevention, health and safety protocols, stakeholder engagement practices, workers' GRM and the requirements for the storage, handling, and disposal of materials and products from the facility.

### **Training Programs**

Facility workers will undergo practical, hands-on training to operate and maintain the bioplastic production equipment. This covers routine operations, troubleshooting, maintenance, and safety protocols. Training on occupational health and safety protocols will be provided for employees to minimize risks associated with production processes. This includes handling raw materials, managing hazardous substances and emergency response.

Employees will be trained in sustainable production practices to reduce resource consumption, minimize waste and optimize the use of raw materials.

### **SEA/SH**

Training to raise awareness regarding SEA/SH, including the factors that lead to SEA/SH and the consequences of SEA/SH will be mandatory for all workers, along with training to mitigate the risk of SEA/SH to ensure a safe environment for the workforce. This will include training in identifying the signs of and reporting of SEA/SH.

### **New Staffing Requirements**

Depending on the scale of operations, additional production technicians with expertise in bioplastic manufacturing are required. Recruitment will be focused on individuals with experience in handling bioplastic production equipment and processes.

During the construction phase, the contractor is required to maintain an environmental and social officer. UNOPS will monitor the implementation of E&S risk mitigation measures through its Environmental and Social Specialist.

During the operational phase, the facility will include the services of an Environmental and Social Specialist to deliver the training and capacity building and to ensure the risk mitigation measures in the ESMP are complied with. UNOPS will continue the monitoring of measures as per the indicators listed in the ESMP.

**Support and Administrative Staff:** A team of administrative and logistical support staff will be recruited to manage operational tasks, documentation, and coordination with stakeholders.

**Capacity Strengthening for Management**

The Facility manager will receive additional training on project management, operational efficiency, and E&S compliance to ensure the smooth operation of the facility.

Managers will also be trained in stakeholder engagement and GRM requirements, with a focus on maintaining open communication with local communities, addressing grievances, and promoting the socio-economic benefits of the facility.

**Ongoing and Continuous Training**

Refresher training sessions will be held annually to ensure staff remain updated on evolving technologies, safety protocols, and environmental and social standards.

The facility will establish partnerships with local and regional training institutions to facilitate ongoing skill development and knowledge sharing in bioplastic production technologies.

**6. Implementation Schedule and Cost Estimates**

The following is a breakdown of the cost estimate for implementing the mitigation and capacity development measures. Contracting of workers will be included in the contractor's BOQ.

The schedule of the construction phase is as follows:

Activities	Month 1	Month 2	Month 3	Month 4	Month 5	Month 6
Site Preparation						
Foundation works						
Ground floor						
First floor						
Mezzanine floor						

Second floor						
Terrace floor						
Machinery installing						
Piloting						

Below are the cost estimates required for the implementation of this ESMP.

Item	Estimated Cost (USD)	Responsibility
Spill kits and containment materials	\$ 1,500	Contractor
PPE (initial procurement)	\$ 1,000	Contractor
Equipment hire	\$ 1,500	SIGS
EHS Officer (per year)	\$ 11,700	SIGS
Miscellaneous (training materials, incidentals)	\$ 500	SIGS
GRM costs	\$ 450	SIGS
Safety signage	\$ 450	SIGS
Training costs	\$ 200	SIGS
<b>TOTAL</b>	<b>\$ 17,300</b>	<b>SIGS</b>

# 7. Attachments

## 7.1 Land Deed

کمیٹی کے احکامات کے تحت

30

60.8

75 75

4548.43

97

60.5

1"=1mm

N

کمیٹی کے احکامات کے تحت

229

(27-11-2017)258/2017/24

مختارہ سیدہ سحر: 229

کوئی سیدہ سحر: (27-11-2017)258/2017/24

مختارہ سیدہ سحر: سیدہ سحر (مختارہ سیدہ سحر سیدہ سحر)

کوئی سیدہ سحر: مختارہ سیدہ سحر

مختارہ سیدہ سحر: مختارہ سیدہ سحر

کوئی سیدہ سحر: مختارہ سیدہ سحر

10-11-1995

مختارہ سیدہ سحر

مختارہ سیدہ سحر: مختارہ سیدہ سحر (مختارہ سیدہ سحر سیدہ سحر)

کوئی سیدہ سحر: مختارہ سیدہ سحر

مختارہ سیدہ سحر: مختارہ سیدہ سحر

کوئی سیدہ سحر: مختارہ سیدہ سحر

10-01-2018

مختارہ سیدہ سحر

مختارہ سیدہ سحر

## 7.2 MOU Clearance

**MEMORANDUM OF UNDERSTANDING**  
BETWEEN  
**WATER SOLUTIONS PVT LTD**  
AND  
**SMALL ISLAND GEOGRAPHIC SOCIETY**

25 MARCH 2024



SMI

## MEMORANDUM OF UNDERSTANDING

This MEMORANDUM OF UNDERSTANDING (the “MoU”) is made on 25 March 2024 by and between Small Island Geographic Society, Reg No: CR/14/2018, having its registered address at: Niyadhurumaage, 4F-B, Male’, Republic of Maldives (as “SIGS”), and Water Solutions Pvt Ltd, Reg No: C-344/2005, having its registered address at: Dhon Umaruge Dhekunubai, Maafannu, Male’, Republic of Maldives (as “WS”).

### Background:

SIGS is engaged in a project to develop and produce eco-friendly bags to replace plastic bags and packaging. WS owns a 4,500 square foot land (WS Corbin) located at HDh. Hanimaadhoo, Maldives.

### Purpose:

The purpose of this MoU is to set forth the terms and conditions under which WS agrees to provide land (WS Corbin) to SIGS for the establishment and operation of an eco-friendly bag production and training facility for the duration of the specified project.

### Terms and Conditions:

**Land Provision:** WS agrees to provide a 4,500 square foot parcel of land (WS Corbin) located at HDh. Hanimaadhoo, Maldives to SIGS for the establishment and operation of an eco-friendly bag production and training facility.

**Duration:** The land (WS Corbin) shall be provided to SIGS for the duration of 10 years, which is expected to commence on 25 March 2024 and conclude on 24 March 2034.

**Usage:** SIGS shall utilize the provided land (WS Corbin) exclusively for the purpose of establishing and operating a bag production and training facility in connection with the aforementioned project.

**Maintenance and Upkeep:** SIGS shall be responsible for the maintenance, upkeep and security of the land during the project duration.

**Compensation:** SIGS shall pay a rental to WS at market rate after a grace period of 1 year. Rental of the land (WS Corbin) shall be negotiated before the end of the grace period, at a rate accepted by both parties.

**Confidentiality:** Both parties agree to treat all information exchanged during the negotiation and execution of this MOU as confidential and shall not disclose such information to any third party without the prior written consent of the other party.

**Investment Retention:** Upon the expiry of this MoU, any investments made by SIGS on the WS land (WS Corbin) for the establishment of the eco-friendly bag production and training facility shall remain the property of SIGS. WS shall provide reasonable assistance to SIGS in facilitating the removal of such assets if required.

**Continuation Agreement:** Should WS intend to continue the operation of the eco-friendly bag production and training facility on the land (WS Corbin) after the expiry of this MoU, both parties shall negotiate in good faith the terms and conditions of a new agreement.



Page 2 of 3

SMH



Termination Clause: Either party may terminate this MoU by providing written notice to the other party at least 2 months prior to the intended termination date. In the event of termination, SIGS shall have 30 days to remove all its investments, equipment, and assets from the WS land. WS shall provide reasonable assistance to SIGS in facilitating the removal of such assets if required. Any outstanding rental payments or obligations shall be settled prior to the termination date.

Signatures:

IN WITNESS WHEREOF, the parties hereto have executed this Memorandum of Understanding as of the date first above written.

**Small Island Geographic Society**

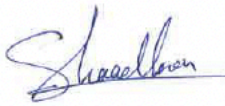

Authorized Signature

Shaadhoon Haleem, Administrative Office

Date: 25 March 2024

**Water Solutions Pvt Ltd**



Authorized Signature

Azzath Faheem, Office Manger

Date: 25 March 2024

7.3 Screening Decision



Environmental Protection Agency  
 ދިވެހިސަރުކާރުގެ ގެޒެޓްގައި ބަޔާންކޮށްފައިވާ ފަރާތްތަކަށް ދެކޮޅެއް ނުވާނެ ގޮތަށް



203-ECA/PRIV/2024/694: ސަރުކާރުގެ ގެޒެޓްގައި ބަޔާންކޮށްފައިވާ ފަރާތްތަކަށް ދެކޮޅެއް ނުވާނެ ގޮތަށް

ސަރުކާރުގެ ގެޒެޓްގައި ބަޔާންކޮށްފައިވާ ފަރާތްތަކަށް ދެކޮޅެއް ނުވާނެ ގޮތަށް

Screening Decision

މި ދިވެހިސަރުކާރުގެ ގެޒެޓްގައި ބަޔާންކޮށްފައިވާ ފަރާތްތަކަށް ދެކޮޅެއް ނުވާނެ ގޮތަށް ސަރުކާރުގެ ގެޒެޓްގައި ބަޔާންކޮށްފައިވާ ފަރާތްތަކަށް ދެކޮޅެއް ނުވާނެ ގޮތަށް (SIGS) ފަރާތްތަކަށް ދެކޮޅެއް ނުވާނެ ގޮތަށް ބަޔާންކޮށްފައިވާ ފަރާތްތަކަށް ދެކޮޅެއް ނުވާނެ ގޮތަށް.

This is an official document issued to Small Island Geographic Society ( SIGS) for communicating the decision made after screening of the project: Proposed development of a biodegradable plastic bag production facility in Hanimaadhoo, Haa Dhaalu Atoll.

<p>މި ދިވެހިސަރުކާރުގެ ގެޒެޓްގައި ބަޔާންކޮށްފައިވާ ފަރާތްތަކަށް ދެކޮޅެއް ނުވާނެ ގޮތަށް ސަރުކާރުގެ ގެޒެޓްގައި ބަޔާންކޮށްފައިވާ ފަރާތްތަކަށް ދެކޮޅެއް ނުވާނެ ގޮތަށް ބަޔާންކޮށްފައިވާ ފަރާތްތަކަށް ދެކޮޅެއް ނުވާނެ ގޮތަށް.</p> <p>This project is likely to cause significant negative environmental impacts. Hence, please submit an EIA report.</p>	<input checked="" type="checkbox"/>
<p>މި ދިވެހިސަރުކާރުގެ ގެޒެޓްގައި ބަޔާންކޮށްފައިވާ ފަރާތްތަކަށް ދެކޮޅެއް ނުވާނެ ގޮތަށް ސަރުކާރުގެ ގެޒެޓްގައި ބަޔާންކޮށްފައިވާ ފަރާތްތަކަށް ދެކޮޅެއް ނުވާނެ ގޮތަށް ބަޔާންކޮށްފައިވާ ފަރާތްތަކަށް ދެކޮޅެއް ނުވާނެ ގޮތަށް.</p> <p>Submit an Initial Environmental Examination for this project.</p>	<input type="checkbox"/>
<p>މި ދިވެހިސަރުކާރުގެ ގެޒެޓްގައި ބަޔާންކޮށްފައިވާ ފަރާތްތަކަށް ދެކޮޅެއް ނުވާނެ ގޮތަށް ސަރުކާރުގެ ގެޒެޓްގައި ބަޔާންކޮށްފައިވާ ފަރާތްތަކަށް ދެކޮޅެއް ނުވާނެ ގޮތަށް ބަޔާންކޮށްފައިވާ ފަރާތްތަކަށް ދެކޮޅެއް ނުވާނެ ގޮތަށް.</p> <p>Submit an Environmental Management Plan for this project.</p>	<input type="checkbox"/>
<p>މި ދިވެހިސަރުކާރުގެ ގެޒެޓްގައި ބަޔާންކޮށްފައިވާ ފަރާތްތަކަށް ދެކޮޅެއް ނުވާނެ ގޮތަށް ސަރުކާރުގެ ގެޒެޓްގައި ބަޔާންކޮށްފައިވާ ފަރާތްތަކަށް ދެކޮޅެއް ނުވާނެ ގޮތަށް ބަޔާންކޮށްފައިވާ ފަރާތްތަކަށް ދެކޮޅެއް ނުވާނެ ގޮތަށް.</p> <p>This project is unlikely to have a significant negative impact on the environment. Hence, you may proceed with the project.</p>	<input type="checkbox"/>
<p>މި ދިވެހިސަރުކާރުގެ ގެޒެޓްގައި ބަޔާންކޮށްފައިވާ ފަރާތްތަކަށް ދެކޮޅެއް ނުވާނެ ގޮތަށް ސަރުކާރުގެ ގެޒެޓްގައި ބަޔާންކޮށްފައިވާ ފަރާތްތަކަށް ދެކޮޅެއް ނުވާނެ ގޮތަށް ބަޔާންކޮށްފައިވާ ފަރާތްތަކަށް ދެކޮޅެއް ނުވާނެ ގޮތަށް.</p> <p>The measures stipulated by this agency shall be used to mitigate the negative impacts of the project.</p>	<input type="checkbox"/>

މި ދިވެހިސަރުކާރުގެ ގެޒެޓްގައި ބަޔާންކޮށްފައިވާ ފަރާތްތަކަށް ދެކޮޅެއް ނުވާނެ ގޮތަށް ސަރުކާރުގެ ގެޒެޓްގައި ބަޔާންކޮށްފައިވާ ފަރާތްތަކަށް ދެކޮޅެއް ނުވާނެ ގޮތަށް ބަޔާންކޮށްފައިވާ ފަރާތްތަކަށް ދެކޮޅެއް ނުވާނެ ގޮތަށް.

This is an environmental screening. Hence, obtain all necessary approvals/permits from other relevant government authorities before commencement of the project activities. The date of expiry stated in this Environmental Screening Decision Statement is the duration given to implement the decision made by this agency.

*Handwritten signature*





Screening Institution: **Environmental Protection Agency of Maldives**

ސަލާޕްރިއަންޓް ޖެނެރަލް ޔުނިޓް ޕްރޮޓެކްޓްޕްރިއަންޓް ޕްރޮޓެކްޓްޕްރިއަންޓް ޕްރޮޓެކްޓްޕްރިއަންޓް ޕްރޮޓެކްޓްޕްރިއަންޓް

Date of issue: **27<sup>th</sup> August 2024**  
Date of Expiry: **27<sup>th</sup> August 2025**

ޖެނަރަލް ޕްރޮޓެކްޓްޕްރިއަންޓް: 27 ޔުލައި 2024  
ޕްރޮޓެކްޓްޕްރިއަންޓް ޕްރޮޓެކްޓްޕްރިއަންޓް: 27 ޔުލައި 2025

Name: **Mr. Ibrahim Naeem**  
Designation: **Director General**



ނަންބަރު: ޕްރޮޓެކްޓްޕްރިއަންޓް ޕްރޮޓެކްޓްޕްރިއަންޓް ޕްރޮޓެކްޓްޕްރިއަންޓް ޕްރޮޓެކްޓްޕްރިއަންޓް  
ޕްރޮޓެކްޓްޕްރިއަންޓް ޕްރޮޓެކްޓްޕްރިއަންޓް ޕްރޮޓެކްޓްޕްރިއަންޓް ޕްރޮޓެކްޓްޕްރިއަންޓް

Signature:  ސަލާޕްރިއަންޓް





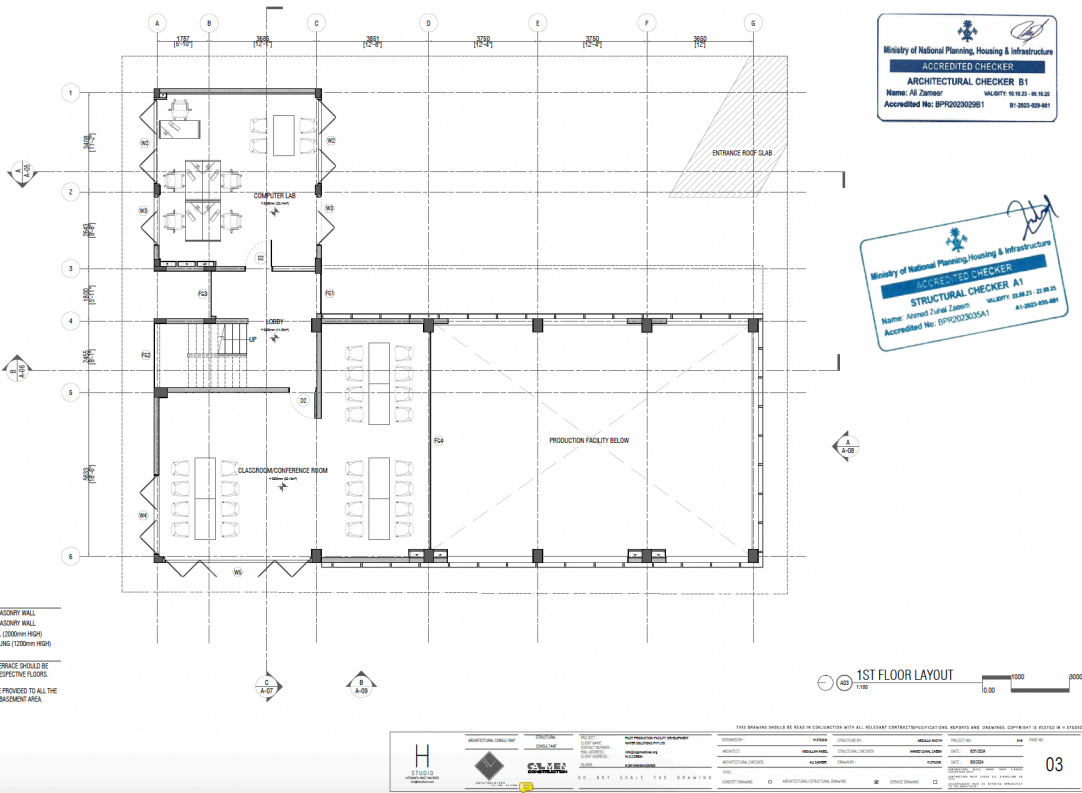
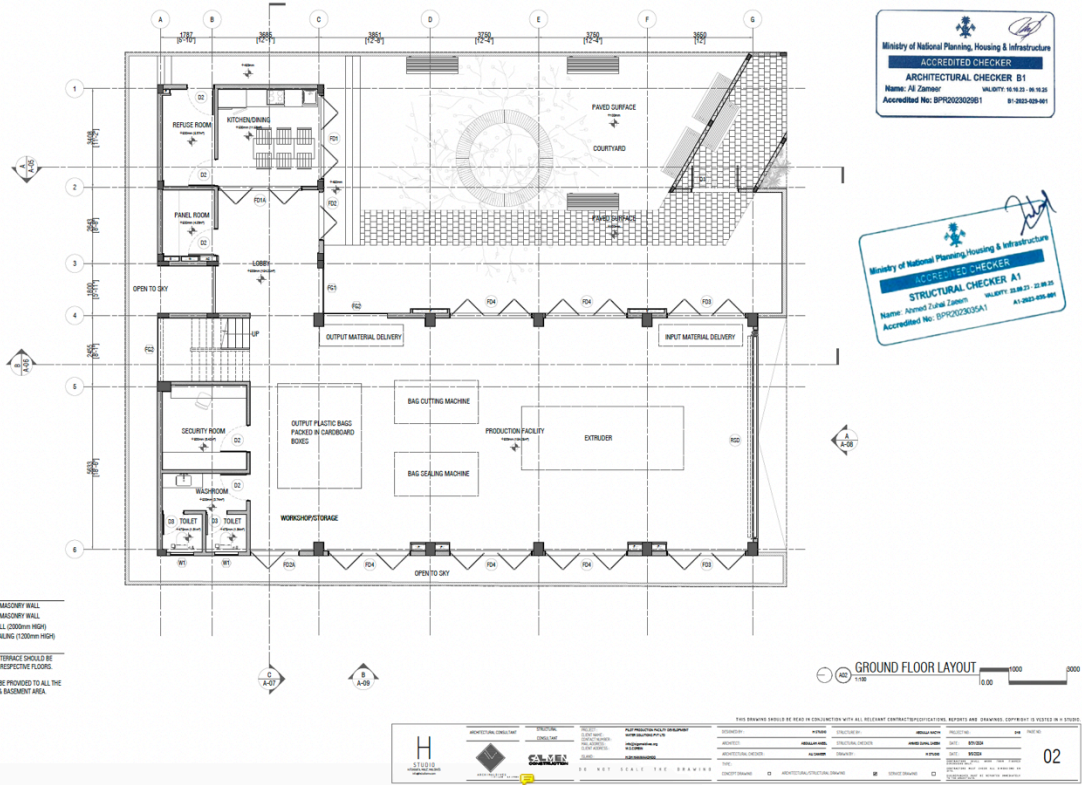

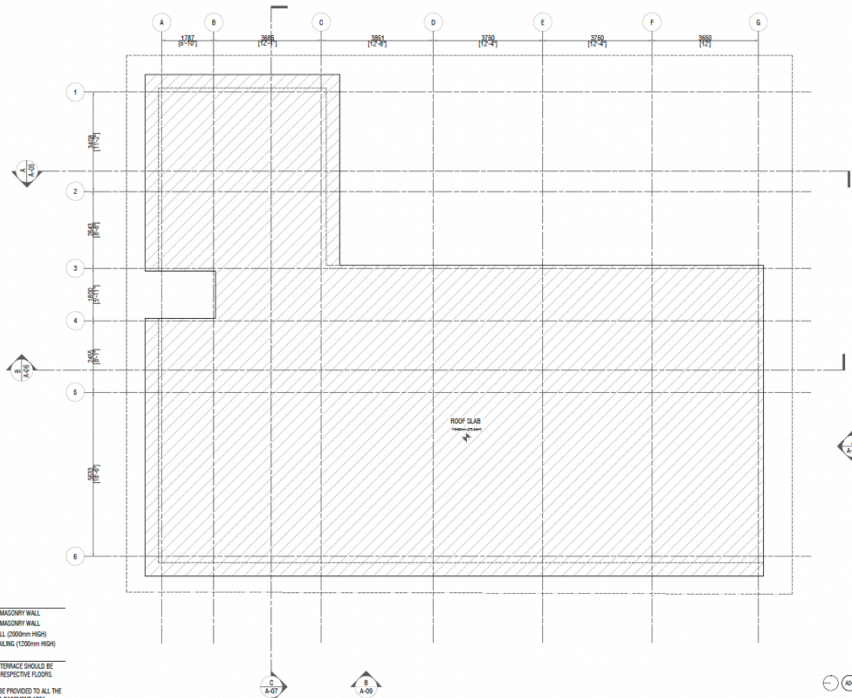

Ministry of National Planning, Housing & Infrastructure  
**ACCREDITED CHECKER**  
**ARCHITECTURAL CHECKER B1**  
 Name: AS Zaman      No. of Reg. 04-03-03      04-03-03  
 Accredited No: BPIQ20200961      01-2023-030-041

Ministry of National Planning, Housing & Infrastructure  
**ACCREDITED CHECKER**  
**STRUCTURAL CHECKER A1**  
 Name: Ahmed Zuhair Zuhair      No. of Reg. 03-08-21      03-08-21  
 Accredited No: BPIQ202005A1      01-2023-030-041

**LEGEND**  
 150mm THICK BLOCK MASONRY WALL  
 100mm THICK BLOCK MASONRY WALL  
 100mm MASONRY WALL (2000mm HIGH)  
 50mm THICK STEEL RAILING (1200mm HIGH)  
**NOTES**  
 - PFL OF TOILETS, BALCONIES & TERRACE SHOULD BE 25mm LOWER THAN THE PFL OF RESPECTIVE FLOORS.  
 - PROPER WATER PROOFING TO BE PROVIDED TO ALL THE TOILETS, BALCONIES, TERRACE & BASINMENT AREA.



THIS DRAWING SHOULD BE READ IN CONJUNCTION WITH ALL RELEVANT CONTRACTS/REGULATIONS, SPECIFICATIONS AND DRAWINGS. COPYRIGHT IS RESERVED BY A STUDIOS.

ARCHITECTURAL CONSULTANT	PROJECT NAME	PROJECT LOCATION	PROJECT NO.	DATE	SCALE
AHMED ZAMAN	AL-SAYED	AL-SAYED	AL-SAYED	04-03-03	1:100
ARCHITECTURAL CHECKER	STRUCTURAL CHECKER	DATE	SCALE		
AS ZAMAN	AHMED ZUHAIR ZUHAIR	04-03-03	1:100		
DATE	SCALE				
04-03-03	1:100				

04



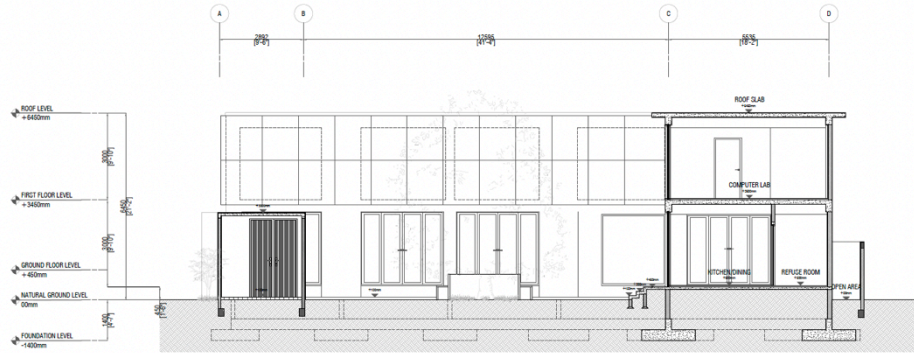

SECTION-A  
1:100

	ARCHITECTURAL CHECKER	STRUCTURAL	PROJECT	PROJECT NAME	PROJECT NO.	PROJECT DATE	PROJECT LOCATION	PROJECT VALUE	PROJECT TYPE
	ARCHITECTURAL CHECKER	STRUCTURAL	PROJECT	PROJECT NAME	PROJECT NO.	PROJECT DATE	PROJECT LOCATION	PROJECT VALUE	PROJECT TYPE
THE DRAWING SHOULD BE READ IN CONJUNCTION WITH ALL RELEVANT CONTRACTS, SPECIFICATIONS, REPORTS AND DRAWINGS. COPYRIGHT IS RESERVED IN ALL RIGHTS.									

05

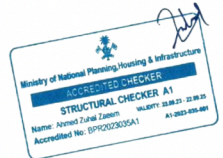
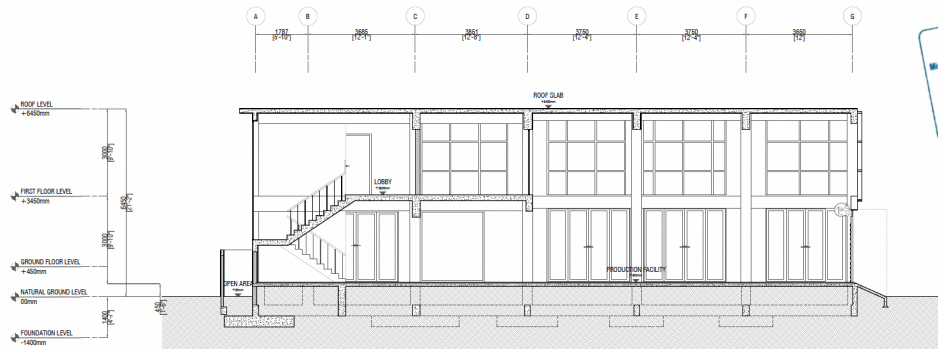

SECTION-B  
1:100

	ARCHITECTURAL CHECKER	STRUCTURAL	PROJECT	PROJECT NAME	PROJECT NO.	PROJECT DATE	PROJECT LOCATION	PROJECT VALUE	PROJECT TYPE
	ARCHITECTURAL CHECKER	STRUCTURAL	PROJECT	PROJECT NAME	PROJECT NO.	PROJECT DATE	PROJECT LOCATION	PROJECT VALUE	PROJECT TYPE
THE DRAWING SHOULD BE READ IN CONJUNCTION WITH ALL RELEVANT CONTRACTS, SPECIFICATIONS, REPORTS AND DRAWINGS. COPYRIGHT IS RESERVED IN ALL RIGHTS.									

06

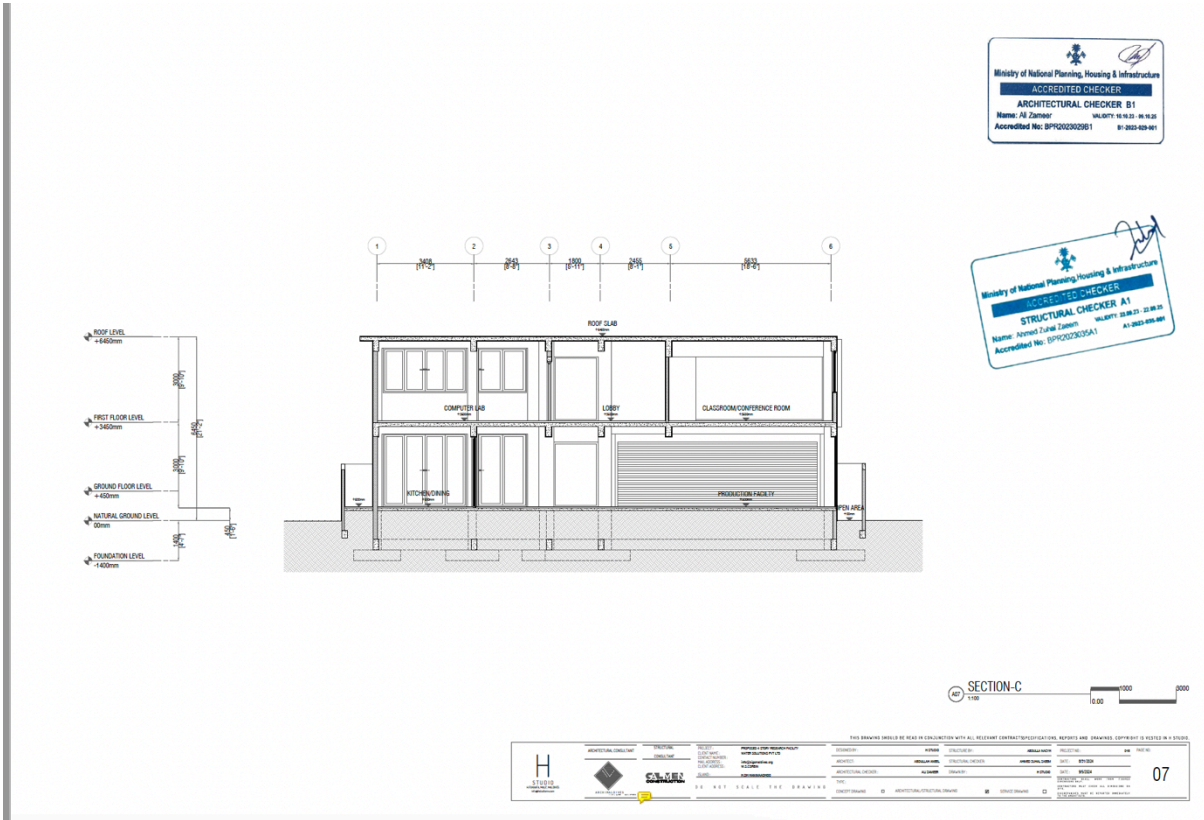

**7.5 Letter from Hanimaadhoo Council**





Secretariat of the Hanimaadhoo Council,  
South Thiladhunmathi

Hdh. Hanimaadhoo, Rep. of Maldives



ދިވެހިރާއްޖޭގެ ޖުމްހޫރިއްޔާ ގުޅިގެން  
ދިވެހިރާއްޖޭގެ ޖުމްހޫރިއްޔާ ގުޅިގެން

ދިވެހިރާއްޖޭގެ ޖުމްހޫރިއްޔާ ގުޅިގެން

Reference No: 258/PRIV/2024/169

Date: 03<sup>rd</sup> September 2024

Ahmed Jameel,  
Vice President,  
Small Islands Geographic Society,  
Male', Maldives

**TO WHOM IT MAY CONCERN.**

The land plot registered under the name “WS Corbin”, located on Maaveyo Magu in Hanimaadhoo Island, Haa Dhaalu Atoll, has been registered to Water Solution Pvt Ltd (Registry Number: 258/2017/24, Plot Number:67) by this Council on January 10, 2018.

The Small Island Geographic Society (SIGS) has proposed developing a pilot production and testing facility for bioplastic bags on the aforementioned land. Hanimaadhoo Island Council warmly welcomes this initiative, as it aligns with our commitment to promoting regional development of the local community.

We are pleased to support this environmentally friendly initiative. The Council would support zoning this area for research and industrial innovation in the island’s land use plan and has no reservations about the pilot production facility being established at this location.

Yours sincerely,

Firaq Mohamed  
Vice President,  
Hanimaadhoo Council



## 7.6 Grievance Redress Mechanisms

In compliance with the Project SEP and GRM, and with ESS10, SIGS proposes to implement a GRM at the Project site.

The GRM will allow individuals or groups from the project-affected communities to raise concerns about the project's social and environmental performance. The mechanism has three tiers, and every effort will be made to resolve grievances amicably before escalating to higher tiers. The following steps will be implemented by SIGS to facilitate the GRM:

- An information board will be installed at the project site in Hanimadhoo, providing contact details.
- A register of grievances will be maintained at SIGS.

### First Tier

- An individual or an interest group can contact SIGS for grievances.
- An Information Board at the project site will list a phone number and an email address for the submission of a grievance. The phone number will be manned by a designated SIGS staff throughout working hours. The email address will be checked at least once a day by the same designated staff.
- The staff will receive the grievance and register it in the designated grievance register for the site. The staff will acknowledge the receipt of the grievance. He or she will then assess whether the grievance is related to the project and will undertake investigations if necessary.
- If the grievance cannot be resolved at this level, the complainant can submit a formal complaint via
  - email to [info@sigsmaldives.org](mailto:info@sigsmaldives.org) or by calling (960) 3341643.
  - SIGS will aim to resolve the complaint within 15 days and provide a written response to the aggrieved party. If more time is needed, SIGS will notify the complainant in writing, request an extension of up to 15 additional days, and obtain the complainant's consent for the extension.

### Second Tier

- If the grievance cannot be resolved through Tier 1, an aggrieved party must submit a complaint on the
  - Tier 2 to Hanimadhoo Island Council.
  - The aggrieved party can contact the Hanimadhoo Island Council at (960) 4002052 or by email at
    - [info@hanimaadhoo.gov.mv](mailto:info@hanimaadhoo.gov.mv).
    - The island council will screen the complaint to determine if it is related to the project.
    - If not related, the complainant will be informed in writing, along with recommendations for appropriate government bodies to contact.
    - If related, the island council will arrange a meeting with SIGS to address the grievance.
    - The island council will issue a written response within 15 working days if a resolution is reached.

- The complainant must acknowledge the decision within 10 days. If no acknowledgment is received, the decision is considered accepted.
- If unsatisfied, the complainant may inform the island council in writing of their intention to escalate to Tier III.

### **Third Tier**

An individual or an interest group has the option of going to established judiciary system of the Maldives.

**SEA/SH:** SEA/SH cases are substantively different from other complaints that are typically handled through the grievance redress mechanisms, their information will be handled in a special way within the GRM to ensure that the information is confidential.

Cases of SEA/SH can be reported through the site-specific GRM. However, additional channels for reporting SEA/SH complaints will be identified and integrated into the GRM. The survivor has the freedom and right to report an incident to anyone: community member; project staff; or a nearby GBV service provider. All relevant staff of SIGS will receive training on handling SEA/SH complaints and referral systems, ideally during the project initiation phase. GRM-relevant staff will be trained on key protocols including referral, reporting and informed consent protocols to receive those cases in an appropriate manner and immediately forward them to the SEA/SH referral system. The Officer responsible for the GRM will ensure appropriate response by: (i) providing a safe caring environment and respect the confidentiality and wishes of the survivor; (ii) if survivor agrees, obtain informed consent and make referrals; and (iii) provide reliable and comprehensive information on the available services and support to GBV survivors.

Beneficiaries and communities will generally be encouraged to report all SEA/SH cases through the dedicated SEA/SH referral system and complaints resolution mechanism. This will be made explicit in all community awareness sessions, as well as be part of the publicly disclosed information. The SEA/SH referral system will guarantee that survivors have access to necessary services they may need, including medical, legal, counseling, and that cases are reported to the police should the survivor choose to do so or if the case requires mandatory reporting.

See below LMP for the workers' GRM in 7.8.

### 7.7 SIGS Gender-based Violence and Sexual Harassment Policy

SIGS has a GBV and Sexual Harassment Policy in place, which is applied for all staff. The policy is as follows:

#### Policy Statement

Small Island Geographic Society (SIGS) is dedicated to ensuring a secure workplace for its employees, free from discrimination of all forms including Sexual Exploitation, Abuse, and Sexual Harassment (SEA-SH) and Gender-Based Violence (GBV). SEA-SH-GBV often leads to lasting psychological and physical impacts, making it critical to prevent such incidences and addressing them effectively.

This policy will be in line with the Employment Act (Law No. 2/2008) the Law on Prevention of Sexual Harassment (Law No. 16/2014) and the Regulation on Prevention of Sexual Harassment (No: 2014/R-377). Any allegation of SEA-SH-GBV will be treated seriously and will be investigated. Disciplinary action will be taken against any individual found to be a perpetrator of SEA-SH-GBV. Any complaints submitted will be treated with confidence and respect. All employees of SIGS, as well as contractors and consultants are obligated to follow this Policy.

#### Definitions

**Sexual Exploitation** is actual or attempted abuse of a position of vulnerability, power, or trust, for sexual purposes. Sexual Abuse is actual or threatened physical intrusion of a sexual nature, whether by force or under unequal or coercive conditions. SH is an unwelcome sexual advance, request for sexual favours or other unwelcome conduct of a sexual nature which makes a person feel offended, humiliated and/or intimidated. It includes situations where a person is coerced to engage in sexual activity to advance that person's employment, and create a hostile, intimidating or humiliating work environment. SEA-SH also occurs in many forms, including physical (unwelcome physical contact, sexual assault) verbal (sexual jokes, flirting) and non verbal conduct (display of sexually suggestive material, whistling), but are not limited to these.

**Child Sexual Abuse** is the perpetration of any form of SEA-SH to a child – defined as any individual under the age of 18. This includes various forms of sexual violence with explicit force or coercion. A child **cannot consent** to any form of sexual activity.

**GBV** is violence targeted towards someone for belonging to a particular gender, and being subject to violence that disproportionately affects those of that gender. GBV may occur in the form of physical (beating, pushing), sexual (SH, suggestive comments), psychological (emotional blackmail) violence, but are not limited to these.

**Consent** is making an informed choice to participate in something willingly and freely. Consent is **not** obtained if:

- Threats, force, coercion, abduction, fraud, manipulation, deception or manipulation was

used.

- A benefit that the person is already entitled to is threatened to be withheld.
- A benefit is provided as a promise.

SIGS recognizes that any individual can be a target of SEA-SH-GBV, regardless of gender, and is committed to ensure that anyone who submits such a complaint will be treated with equal respect and dignity. SEA-SH-GBV may occur in unequal power relationships (supervisor and mentor), which will be taken very seriously if it occurs. All forms of GBV and SH are prohibited, not only in the SIGS office premises, but also at public events, field trips, training sessions and online forums.

### **Complaints Procedure**

Any individual who experienced SEA-SH-GBV is encouraged to inform the perpetrator that their conduct is unwanted and unwelcome.

A designated point person will be assigned, who will receive any SEA/SH-GBV complaints. This is a person sensitized on privacy issues, accessible communication on resources on seeking help on GBV whether it happens at workplace or home. When a complaint is received by the point person, they must do the following:

- Immediately record the dates, times and facts of the incident(s).
- Ascertain the views of the victim as to what outcome he/she wants.
- Ensure that the victim understands SIGS procedures for dealing with the complaint.
- Keep a confidential record of all discussions.
- Respect the choice of the victim.
- Ensure that the victim knows that they can lodge the complaint outside of the SIGS.

For more serious issues, a Task Force consisting of 3 members will be designated to investigate the matter. This Task Force will be selected for a case when needed and will be adjourned when the case is closed.

The Task Force and the designated point person who receives SEA-SH-GBV complaints will be guided by the following principles for their deliberations and recommendations:

- Be people centered: Ensure that the incidence is evaluated through a survivor-centered lens and prioritize the survivor's safety and wellbeing.
- Emphasize prevention: Educate all employees on preventing SEA-SH-GBV incidences and use risk-based approaches.
- Be evidence-based: Use research and best practices for informing recommendations.
- Focus on organizational culture and individual behavior change.
- Use accountability wisely: Find a balance between well-defined accountabilities and shared solutions to avoid creating a culture of risk aversion.

## **Sanctions and Disciplinary Procedures**

An individual found to be a perpetrator of SEA-SH-GBV are liable to the following:

- Verbal or written warning
- Adverse performance evaluation
- Reduction in wages
- Demotion
- Suspension
- Dismissal

The nature of the disciplinary action taken will depend on the gravity of the conduct carried out.

## **Implementation of the Policy**

SIGS will ensure that all employees are made aware of this policy by taking the appropriate measures. A session will be held for all employees on SEA-SH-GBV to prevent such incidents and to help employees understand the steps to be taken if such an incident occurs. Further, any new employees joining SIGS will be briefed on the policy during orientation.

## **Monitoring and Evaluation**

SIGS is committed to monitoring this SEA-SH-GBV policy and will collect data on how it's used and its effectiveness. Those responsible for dealing with SEA-SH-GBV cases, including the designated point person and Task Force members will be required to report on compliance with this policy. These individuals will report on the number of incidences, how they were dealt with, and the actions that were taken. SIGS will also collect feedback from victims to understand if appropriate measures were taken regarding the incident. This information will be used to evaluate the effectiveness of this policy and make any changes needed.

## **Annexure: World Bank Recommendation**

SIGS will follow the Recommendations of World Bank Investment Projects<sup>1</sup>in handling SEA SH-GBV incidences.

<sup>1</sup>Working Together to Prevent Sexual Exploitations and Abuse: Recommendations for World Bank Investment Projects. (2017). World Bank Grou

## **7.8 Labour Management Procedure**

**This annex presents the sections of the** Labour Management Procedure (LMP) that was developed for the Replacing Plastics in our Coastal Environment (REPLACE) Project that are relevant to this site-specific sub-project. For an overview of the labor legislation, see the REPLACE LMP.

### **Assessment of key potential labour risks for Contracted Workers**

#### General risks

- Discrimination based on gender, marital status, age, or any other physical or mental attribute.
- SEA/SH
- Physical and verbal harassment and workplace bullying.
- Discrimination in relation to opportunity/access for training and self-development.
- Discrimination on pay based on nationality, gender or any other aspect not related to experience or
- education.
- Employing a staff without a valid work permit. This is particularly an issue in the construction industry not within the government.

#### Work site risks

- Damage to lungs and health from emissions from construction equipment.
- Prolonged exposure to loud noise from equipment could lead to hearing damage.
- Injury to workers due to an accident involving tools and equipment.
- Exposure to harmful chemicals.
- Dehydration and over exhaustion leading to serious health complications.
- Risk of falling, and risk from falling objects while working at height.
- Poor waste disposal can lead to disease and harm to workers.

### **Policies and procedures**

This section covers the key policies which will be implemented to minimize and address the risks identified

#### Contracted workers

##### General provisions

- List of workers to be utilized in relation to the project, with proof of employment will be required
- to be submitted to PMU by all investors/contractors.
- Construction work can only commence once the following conditions are met: Toolbox training completed by all staff employed by the contractor
- All the required Personal Protective Equipment are acquired by the contractor for all workers

- Any newly employed party by the contractor will be required to complete the toolbox prior to commencing any physical work.
- An internal transparent and accountable system will be established within the company to tackle issues of sexual harassment, physical and psychological harassment and workplace bullying.
- Details of this system will be shared with PMU prior to signing any contracts or agreements.
- All contracted staff will be made aware of grievance redress mechanism available for the staff specified under this LMP.
- The leave policy of the company will be shared and confirmed that it is in line with national laws and regulations.
- All foreign parties employed by all contractors/investors will have valid work permits. The work permit details will be shared with PMU.
- All vehicles used by any contractor/investor for the purpose of the project will have valid registration, insurance, and roadworthiness.

#### At work site

All provisions that are required under the Health and Safety Regulation for the Construction Industry

- (2019/R-156) will be strictly adhered to.
- All workers will be provided with Personal Protective Equipment (PPE) by the contractor/investor.
- In this regard, the following will be observed:
- Hard hats should be used by all workers when undertaking construction and when undertaking inspections at height.
- Enclosed safety shoes should be worn by all construction workers.
- Safety harnesses should be used by all workers when climbing heights at project sites.
- Electrical Protective gloves should be provided to workers when dealing with electrical components.
- Chemical protective gloves should be provided to all workers when dealing with any chemicals.
- Construction safety goggles should be worn by all construction workers.
- Ear plugs should be worn by all construction workers working in environments with high noise (working above 75 decibels).
- Masks should be worn when dealing with chemicals and when working in dusty environments.
- All chemicals should be labeled and stored separately.
- Drinking water will be made available at the construction site.
- Safety signs will be installed at the site, and lights will be installed to ensure clear visibility all hours.
- Waste will be stored and separated based on waste type and transported to the islands' waste facility regularly.
- Any vehicles or equipment used in this project will be used by trained personnel.



## Workers' GRM for contractor and SIGS workers

Tiers of Grievance Mechanism	Contacts, Communication and Other Facilitation by Project	Timeframe to address grievance
First Tier: Contractor	As per the established system of the contractor.	As per established norms of the contractor (not exceeding 30 days).
Second Tier: Labour Relations Authority	If the aggrieved party is not happy with the response from the Contractor/Investor, the party may upgrade the grievance to second tier (i.e. Labour Relations Authority). The aggrieved person may submit the complaint through: <a href="https://lra.gov.mv/submit-acomplaint-form/">https://lra.gov.mv/submit-acomplaint-form/</a>	As per the established norms of the Authority
Third tier: Judiciary	An individual or an interest group has the option of going to established judiciary system of the Maldives. <ul style="list-style-type: none"> <li>● The legal system is accessible to all.</li> <li>● SIGS will provide assistance to vulnerable persons, as defined by this GRM.</li> <li>● In cases where vulnerable persons cannot access the legal system, the Attorney General's Office will provide legal support.</li> <li>● The verdict of the courts will be final.</li> <li>● For the purposes of this project, a vulnerable person is defined as someone who is poor, physically or mentally disabled, destitute, disadvantaged due to ethnicity or social reasons, an orphan, a widow, a person over 65 years old, or a female head of household.</li> </ul>	As per established judicial procedures in Maldives









terminate it. In such circumstances the proponent shall write to the Minister for an extension clearly stating out the reasons for the delay.

- iii. The Minister, or his designate, may issue a cessation order requiring persons working on a Development Proposal to cease working until the order is withdrawn, if:
  - a) This Environmental Decision Statement has been withdrawn or;
  - b) There has been a breach of the conditions of this Environmental Decision Statement.
- iv. It is the Developer's responsibility to undertake all project activities in accordance with the relevant laws and regulations of the Maldives.
- v. The Developer shall submit environmental monitoring report as outlined in Paragraph viii of this Environmental Decision Statement. Failure to submit the requisite monitoring report may result in the suspension or

*(Handwritten signature)*



revocation of the permit under this Decision Statement.

- vi. The Developer is aware that under the National Environment Protection Act (Law no. 4/93) and the Environmental Impact Assessment Regulations the Ministry reserves the right to terminate any activity without compensation if found that such an activity has caused significant, irreversible impacts on the environment.
- vii. All mitigation measures proposed in the EIA report for all the phases of the project shall be fully implemented.
- viii. The environmental monitoring program outlined in the Environmental Impact Assessment Report shall be undertaken and implemented and summary environmental monitoring reports shall be submitted to the Ministry.

*Handwritten signature*



- ix. The date of expiry stated in this Environmental Decision Statement is the duration given to commence the project activities approved under this Environmental Decision Statement.
- x. Once the project activities have started, the Proponent must inform the Environmental Protection Agency, the date of commencement of project activities.

Date of Issue: 19 <sup>th</sup> November 2024		19 نوڤمبَر 2024
Date of expiry: 19 <sup>th</sup> November 2025		19 نوڤمبَر 2025
Name: Mr. Ibrahim Naeem		ނަންމު: އިބްރާހިމް ނަޔީމް
Designation: Director General		ޤައުމީ ގެޒެޓްގައި ބަޔާންކުރި ޖެނެރަލް ޑައިރެކްޓަރު
Signature:		ސަފްތާ:

## 7.10 Review & Approval

**Prepared By:** Ibrahim Faiz

Position: Environmental Consultant Date 7<sup>th</sup> October 2024

**Reviewed By:**

Mohamed Hamdhaan Zuhair



Position: Project Manager (UNOPS Maldives  
Country Team, Please Project)

Date: 21.11.2024



**Approved By:** [Kapila Mahesh Rajapaksha](#)

Position: Environmental and Social  
Development Specialist

Date 21.11.2024